

NPS ARCHIVE
1962
STREIT, J.

DESIGN AND CONSTRUCTION OF A
STEADY STATE PLASMA STUDY FACILITY.

JOHN B. STREIT
and
WALTER E. OLSEN

LIBRARY
U.S. NAVAL POSTGRADUATE SCHOOL
MONTEREY, CALIFORNIA

DUDLEY KNOX LIBRARY
NAVAL POSTGRADUATE SCHOOL
MONTEREY, CALIFORNIA 93943-5002

DESIGN AND CONSTRUCTION
OF A STEADY STATE
PLASMA STUDY FACILITY

* * * * *

John B. Streit
and
Walter E. Olsen

DESIGN AND CONSTRUCTION
OF A STEADY STATE
PLASMA STUDY FACILITY

by

John B. Streit

Lieutenant, United States Navy

and

Walter E. Olsen

Lieutenant, United States Navy

Submitted in partial fulfillment of
the requirements for the degree of

MASTER OF SCIENCE
IN
PHYSICS

United States Naval Postgraduate School
Monterey, California

1962

NPS Archive

1962

Streit, J.

~~5875~~

LIBRARY
U.S. NAVAL POSTGRADUATE SCHOOL
MONTEREY, CALIFORNIA

DESIGN AND CONSTRUCTION
OF A STEADY STATE
PLASMA STUDY FACILITY

by

John B. Streit

and

Walter E. Olsen

This work is accepted as fulfilling
the thesis requirements for the degree of

MASTER OF SCIENCE

IN

PHYSICS

from the

United States Naval Postgraduate School

ABSTRACT

The plasma study facility was conceived as a steady state, highly ionized plasma system for use by the plasma physics group of the Physics Department of the U.S. Naval Postgraduate School, Monterey, California. The primary objectives will be the study of electro-magnetic, Alfvén and ion waves in a plasma, electron and ion beam interactions, and the diffusion of the plasma in magnetic fields. Various diagnostic techniques are envisioned, including Langmuir and magnetic probes, microwave, and spectroscopic measurements.

The plasma column is nine feet long and about two cm in diameter, depending upon the magnitude of the longitudinal magnetic field. It is contained in a pyrex glass cylinder four inches in diameter with access ports every 14 inches for diagnostic equipment. The system is designed to operate at a source gas pressure of approximately one to five microns utilizing differential pumping of neutral particles. The first mode of operation will employ a hollow cathode reflex arc discharge. It is expected that the discharge will carry up to 150 amps at approximately 100 volts. The longitudinal magnetic field in the plasma column will be variable up to 10,000 gauss, and homogeneous to within 2.5% along the axis of the plasma column.

Design and details of construction (except for the field coils and field power supplies) are presented with operating instructions and expenditure data.

The writers wish to express their appreciation for the technical supervision given by Professor N.L. Oleson and Professor A.W. Cooper, and for the assistance of Mr. Michael O'Dea and Mr. Robert Smith.

Table of Contents

| <u>Title</u> | <u>Page</u> |
|--|-------------|
| Introduction | 1 |
| Table of Symbols | 3 |
| The Arc Discharge | 4 |
| The Magnetic Field | 14 |
| The Vacuum System | 15 |
| Mechanical Structure | 19 |
| Appendix A: Operating Instructions and Recommendations for Future Modifications | 23 |
| Appendix B: Vacuum System, Component Specifications and Calculations | 27 |
| Appendix C: Tabulation of Cost Data | 31 |
| Bibliography and References | 32 |

List of Illustrations

| <u>Figures</u> | <u>Page</u> |
|--|-------------|
| 1. Plan View of Vacuum Chamber, and Field Coils | 5 |
| 2. Cathode Assembly | 6 |
| 3. First and Reflector Anodes | 8 |
| 4. Main Control Console Wiring - Block Diagram | 10 |
| 5. Power Supplies and Discharge Control - Wiring Details | 11 |
| 6. Interlocks-Wiring Details | 12 |
| 7. Control Panel | 13 |
| 8. Schematic of Vacuum System | 16 |
| 9. Loading Diagram for Mechanical Structure | 20 |
| 10. Composite Photographs of Machine and Associated Equipment | 21 |

Introduction

The plasma study facility will bring to the Physics Department of the US Naval Postgraduate School, Monterey, California a research tool wherein extensive investigations of the characteristics of highly-ionized, steady-state plasmas may be conducted. Other plasma systems were studied and their most profitable features were combined and employed in this facility. Embodied in the design are:

A magnetic field variable up to 10,000 gauss with no more than a 2.5% axial variation over approximately five feet of the nine foot long plasma column. The field distribution includes a magnetic mirror at one end with a minimum mirror ratio of 1.33 for maximum field conditions.

A differential vacuum pumping scheme resulting in a neutral pressure of 10^{-3} mm Hg at the cathode end of the plasma column and a 10^{-6} mm Hg at the reflecting anode.

Five access stations for diagnostic equipment, evenly spaced over each side of the constant magnetic field portion of the column.

A high degree of flexibility in changing the length of the plasma column, the location of vacuum system components, the position of magnet coils with respect to the chamber, and the type of cathode source.

The above features invite research into the following fields:

Diffusion across a magnetic field.

Propagation of electro-magnetic and plasma-ion waves.

Generation and propagation of Alfvén waves.

Interaction of ion and electron beams with the plasma.

Diagnostic techniques investigating the above will involve microwave, spectroscopic, and Langmuir and magnetic probe measurements.

This report presents the design and details of construction of the arc discharge electrical circuits, components, and power supply including the cathode source; the vacuum system including all associated power supplies, cooling water and high pressure air plumbing; each of the foregoing with necessary controls, metering, and interlocks; and the mechanical structure of the vacuum chamber and support of the system. Although formulation of the magnetic field requirements is discussed, the design of the magnet coils to produce such a field was not undertaken by the

authors. A thorough investigation of coil design including power supplies and water cooling requirements, was made by Prof. A.W. Cooper of the US Naval Postgraduate School and is available under separate cover. ¹

The cost of the plasma facility is exceedingly low compared to other operating systems of comparable size and objective. The total cost to place the machine into operation will be approximately \$85,749 exclusive of measuring equipment. This includes \$64,700 for the magnetic field coils, their associated power supplies and water cooling service. Funds for the preceding figures are appropriated by the Office of Naval Research. The foregoing does not include \$3,366 utilized to bring electrical, water and air services to the laboratory. Installation of these services is to be accomplished by the Public Works Department of the US Naval Postgraduate School and is funded by Maintenance and Operations appropriations. Cost tabulations are presented in the Appendix.

At the time of the completion of the writing of this report, the system was not operating with a discharge because of the lack of electrical power services. Hence all performance parameters alluded to, such as voltage, current, or gas flow rates, are only those anticipated. All the control and interlock equipment, electrodes, and vacuum chamber and system hardware have been assembled and installed. The system is presently in the status of being leak tested. Specifications for the magnet field coils and associated equipment have been sent out for bids.

As this report serves as a summary of laboratory employment and research and will culminate the association of the graduate student-authors with this project, an appendix is included to provide operating instructions for other students newly acquainted with the system and recommendations for possible future modifications to improve system efficiency.

List of Symbols

| | |
|-------------------|---|
| C | Conductance of vacuum system component. |
| D | Diameter of pipe, vacuum plumbing. |
| l | Length of pipe, vacuum plumbing. |
| L | Length of elbow, vacuum plumbing. |
| \bar{p} | Mean pressure in length of pipe. |
| Q | Throughput |
| $Q_{b-cvc\ dp}$ | Effective throughput of baffle and CVC diffusion pump assembly. |
| $Q_{b-veeco\ dp}$ | Effective throughput of baffle and Veeco diffusion pump assembly. |
| R | Magnetic mirror ratio. The ratio of maximum axial mirror field to axial magnetic field in the column. |
| S | Pumping speed. |
| S_p | Speed of vacuum pump. |
| $W_{ o}$ | Energy of particle parallel to axis in constant field portion of column. |
| $W_{ m}$ | Energy of particle parallel to axis in magnetic mirror peak portion of column. |
| $W_{\perp o}$ | Energy of particle perpendicular to axis in constant field portion of column. |

The Arc Discharge

The electrode configuration is as shown in Fig. 1, with a grounded cathode and a positive potential on the first anode. The second anode floats at about ground potential as does the brass cylinder containing the cathode. Operation of the arc is then in the reflex mode. An axial magnetic field up to 10,000 gauss will be employed in the plasma column with a magnetic mirror having a mirror ratio equal to 1.33 minimum. Differential pumping is established by the location of the diffusion pumps and the magnetic mirror.

A diagram of the tantalum, hollow, cylindrical cathode is shown in Fig. 2. The design is very similar to that used by Luce.² Helium input at less than 219 cc/min at 30 psia input pressure is considered sufficient to provide the ion current desired. The helium gas must pass through six cm of the tube before entering the vacuum chamber. This, and the fact that a hot spot about one cm long in the tube is expected to occur² will enhance the probability of ionization. Generated heat is conducted away by immersing the cathode base in a water jacket and swirling cooling water around it at a flow rate of one gpm. The water temperature in the output cooling line is interlocked into the arc power supply to provide a cut-out for excessive heating. In the cathode base, provision is made to mount tantalum tubing of various diameters. The tubing presently installed is one-half inch in outside diameter and .02 inches in wall thickness. All threads are slotted to decrease pump-down time. The four inch diameter brass cylinder containing the cathode source is electrically insulated from the cathode by a viton gasket and fiber bolts.

The highly ionized gas leaves the cathode at a pressure of a few microns. The annular first anode at a potential near 100 volts sustains the discharge. The concentric hole in the copper anode, being 2.5 cm in diameter, limits the diameter of the plasma column passing through it. Water cooling is provided by copper tubing concentric around the anode. Flow rate is about 0.2 gpm. Insulation of the anode in the water cooling lines is provided by neoprene rubber hose.

The second anode at the extreme end of the column is a copper disc three inches in diameter, which floats electrically, and acts as an

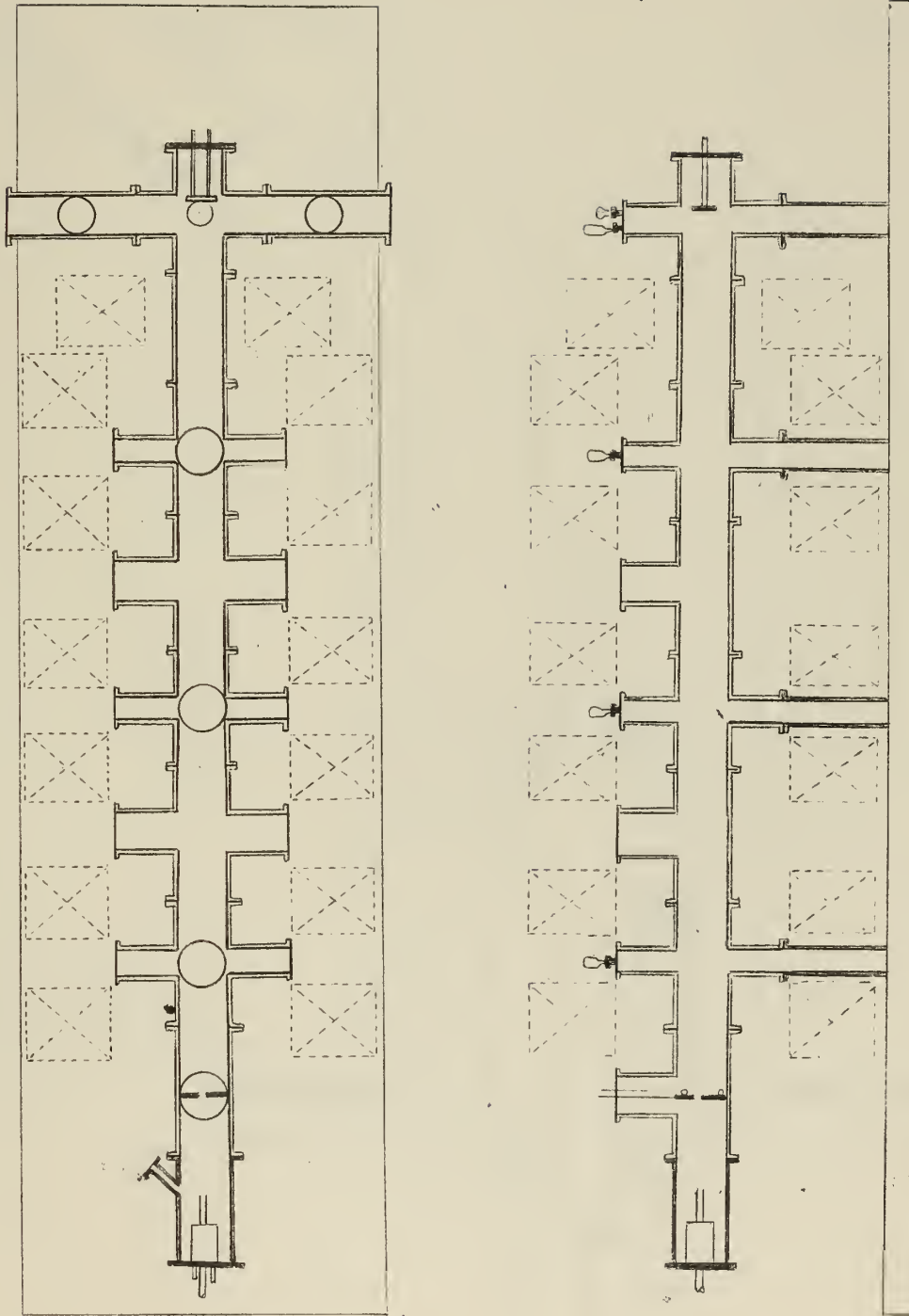







Fig. 1. Plan View of Vacuum Chamber and Field Coils

-  Boron Nitride
-  Brass
-  Copper
-  Quartz
-  Viton

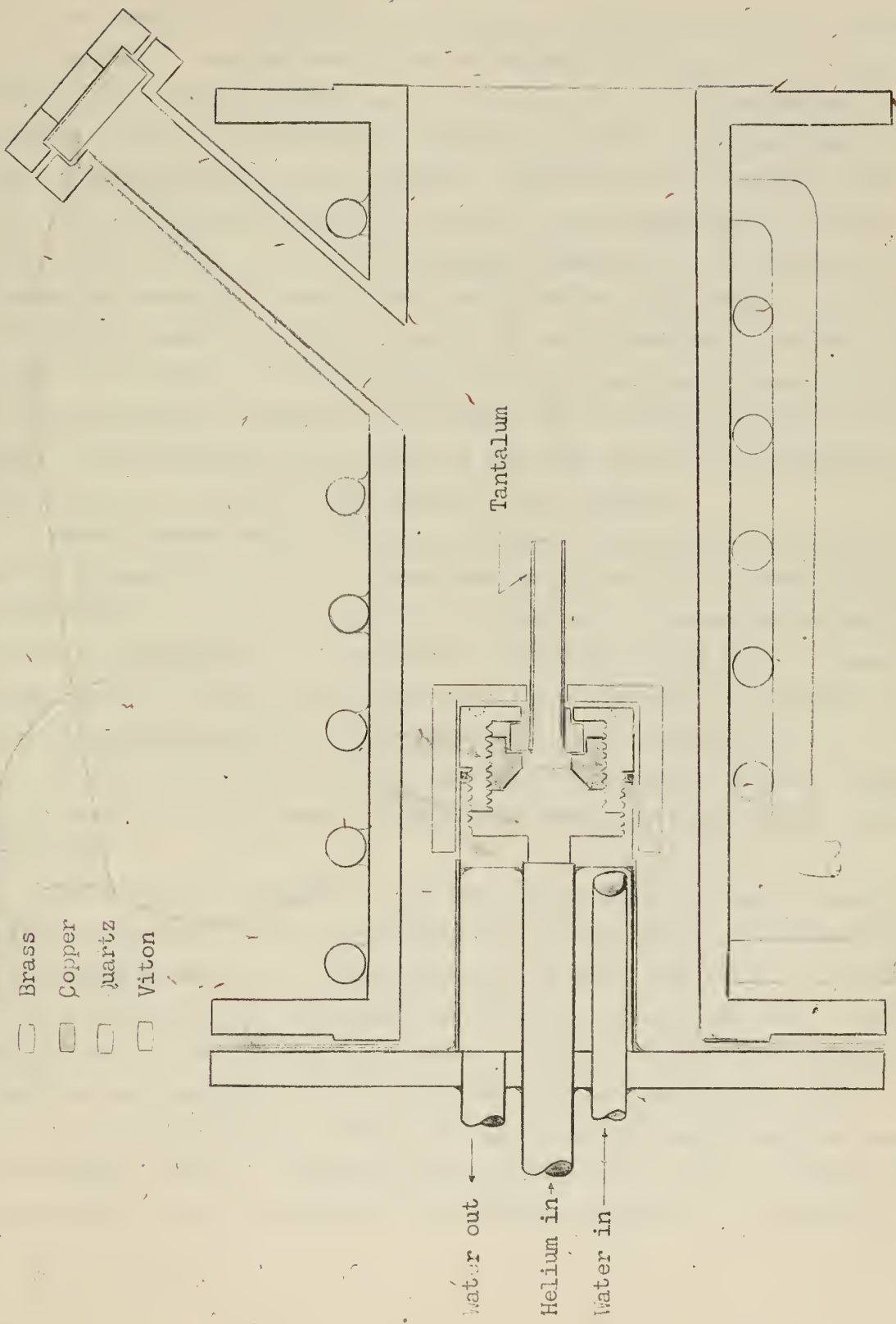

Fig. 2. Cathode Assembly

electron reflector. This electrode is water cooled with a water supply of about 0.1 gpm. The use of neoprene rubber hose again provides insulation. For a sketch of both anodes, see Fig. 3.

The benefits of differential pumping are evident in the P-4 machine at Livermore³ and the Mode II arc of Neidigh and Weaver.⁴ The location of the diffusion pumps and the booster pump of the system under discussion is such as to establish a pressure gradient along the discharge. The recombination rate will be greater toward the anode reflector and the neutrals will pass through the mirror to be pumped out by the combined action of the two diffusion pumps at that end of the column. Following the vernacular used in describing the P-4, this region may be termed the "burial chamber". Neutral density in the column should be about 10^{-5} mm Hg at this point. The placement of the booster pump closer to this end of the column will also aid by increasing the efficiency of these diffusion pumps. An advantage of the system is that the position of the magnet mirror coils is flexible with respect to the chamber.

Washer-shaped baffles between each pair of pump-down ports are inserted perpendicular to the column axis to assist in differential pumping. The diameter of the concentric hole in each baffle through which the plasma passes is presently 0.5 cm smaller than the hole in the anode. Boron nitride, having a small vapor pressure, a low coefficient of expansion, and good insulating properties, was chosen as the baffle material.

As reported in the discharge density investigation of the P-4 machine, the plasma itself can also be expected to pump neutral particles very effectively.³

For starting, breakdown of the gas may be brought about by supplying energy to electrons via rf oscillations in the presence of a magnetic field. A frequency of 100 kc to a few megacycles at about 30^V rms in a field of a few hundred gauss is considered sufficient to ionize the gas. A spark-gap generator found in the Airco welder starter, model HF-15-1, superimposes the necessary rf on a dc potential of approximately 100 volts. A coil to provide 200 gauss will be placed around the source area to supply the necessary field. A helium inflow of about one atm/cc sec would also be necessary. After breakdown, the rf may be removed or, alternately,

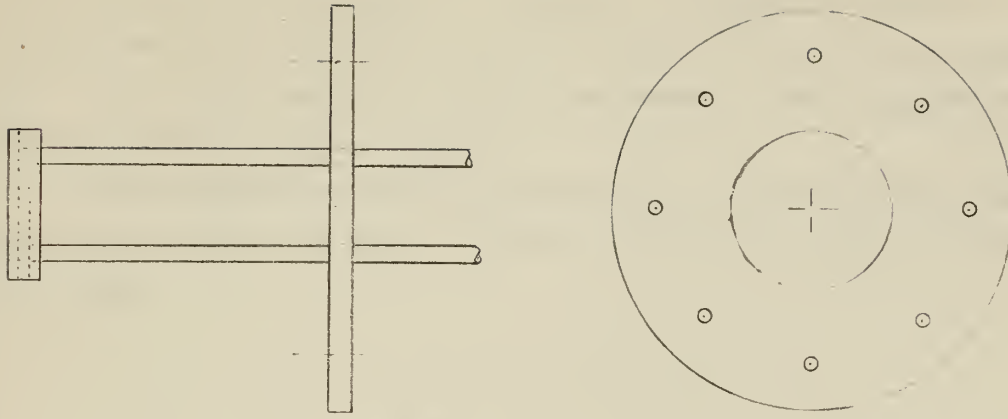

a. Reflector Anode

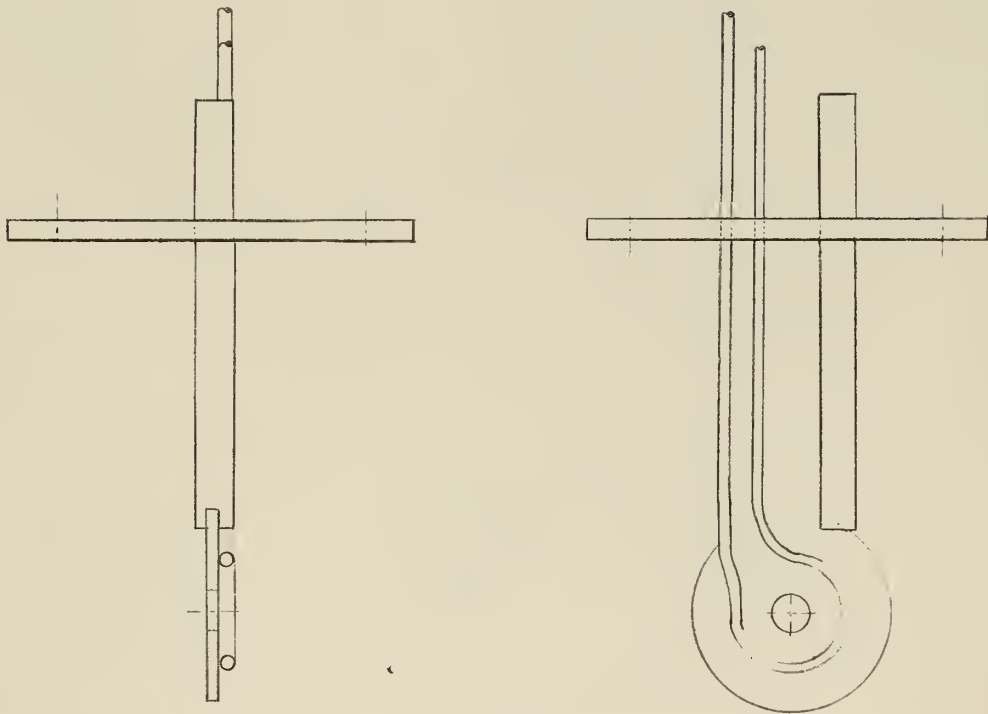

b. Anode

Fig. 3. First and Reflector Anodes

decreased in order to serve as a "keep alive". This latter case would enable a reduction in the dc anode-cathode potential but might introduce oscillations into the plasma. In order to isolate the energy of the rf oscillations from the cathode base and limit it to the area between the tip of the cathode and first anode, the cathode base is capped by a boron-nitride insulating shield.

Block diagrams and wiring detail of the control and interlock circuits are presented in Figs. 4,5 and 6. Fig. 7 is a sketch of the control panel.

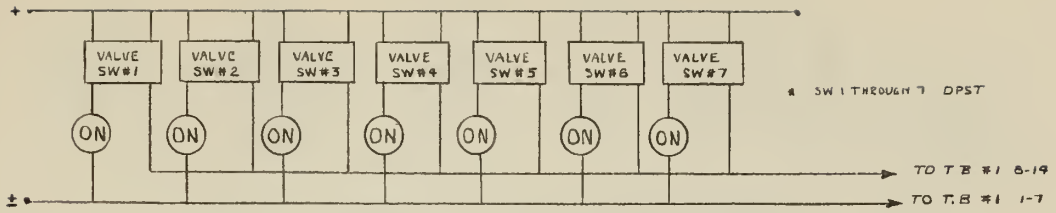

a. Switch and Indicator Circuit for Gate Valves

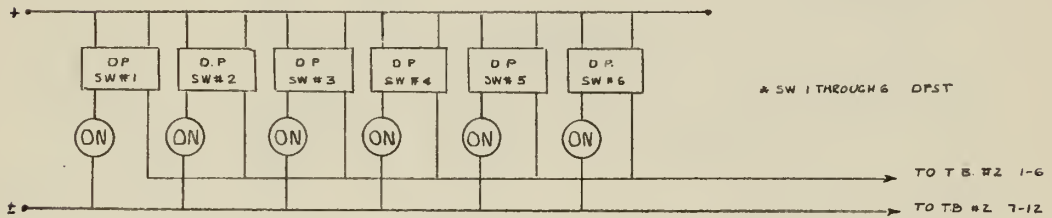

b. Diffusion Pump Heater Switch and Indicator Circuit

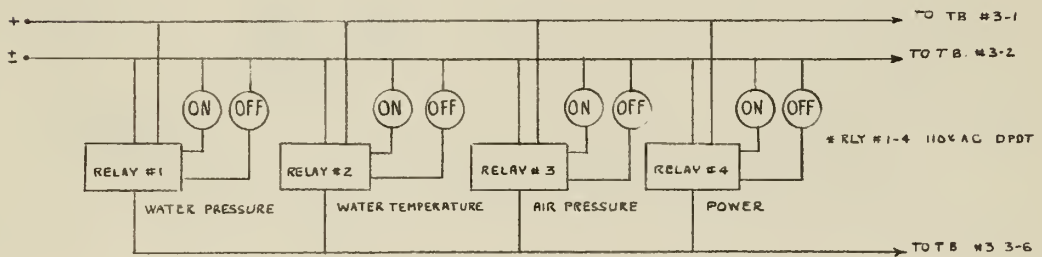

c. Vacuum System Interlock Indicator Circuit

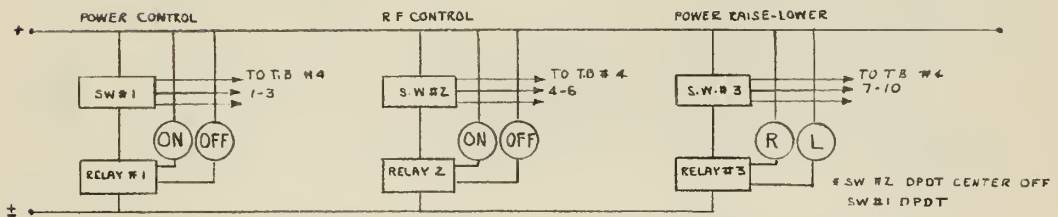

d. Arc Control Panel and Indicator Circuit

Fig. 4. Main Control Console Wiring - Block Diagram

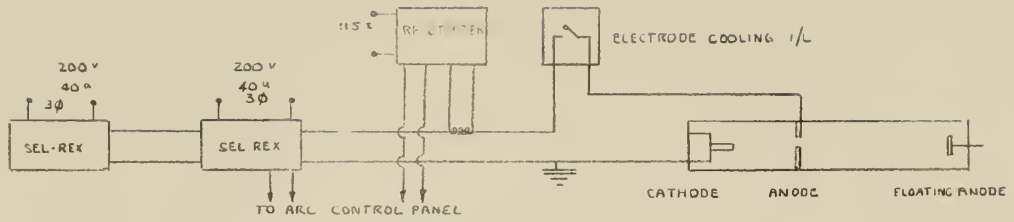

a. Schematic, Plasma Source Power

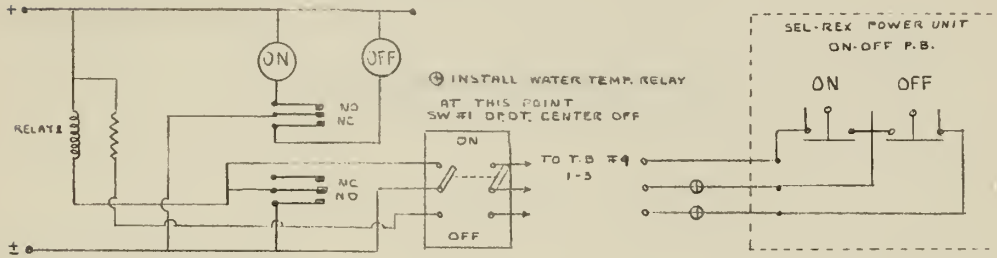

b. Arc Control Panel - Power on-off

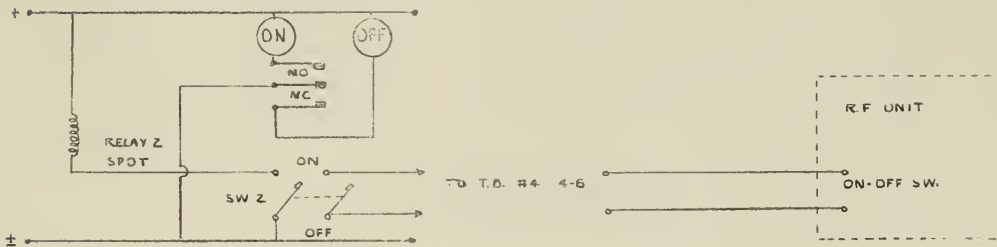

c. Arc Control Panel - rf on-off

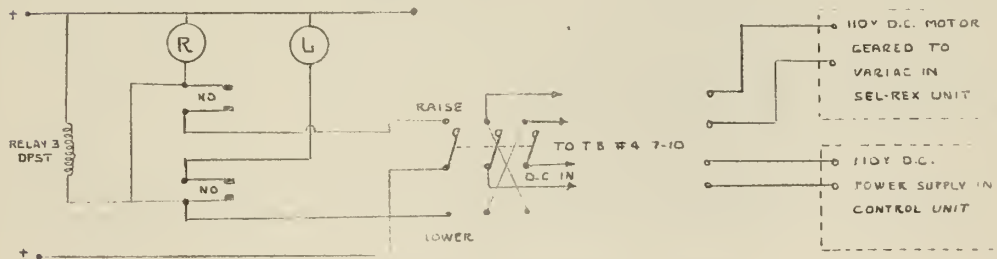

d. Arc Control Panel - Power raise-lower

Fig. 5. Power Supplies and Discharge Control - Wiring Details

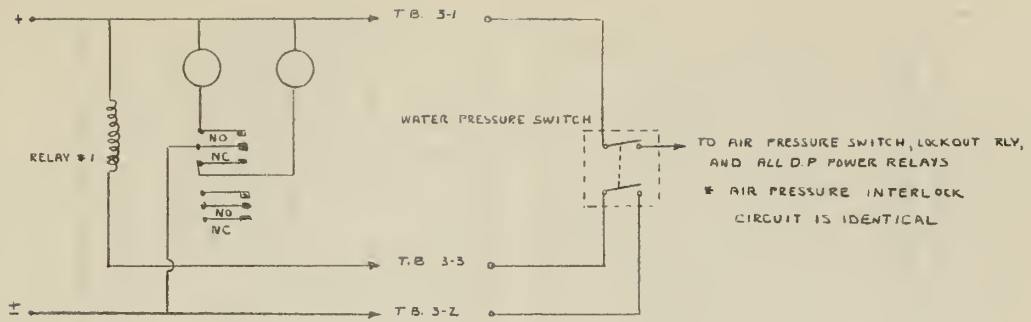

a. Interlock Panel Relay

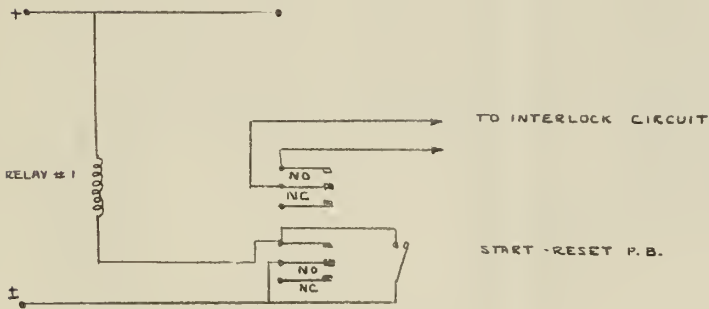

b. Lockout Relay

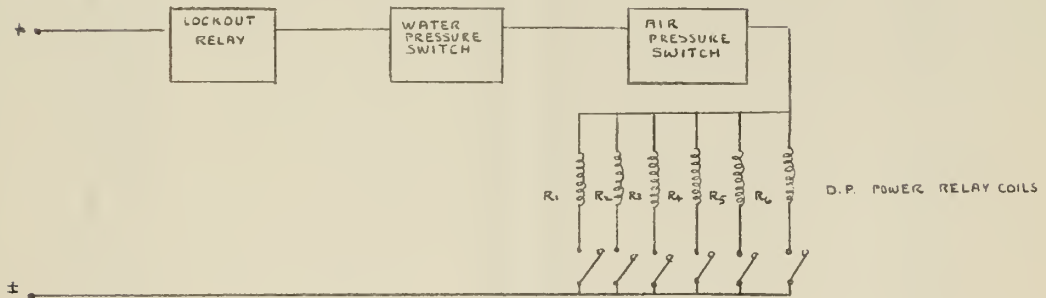

c. Interlock Control Wiring

Fig. 6. Interlocks - Wiring Details

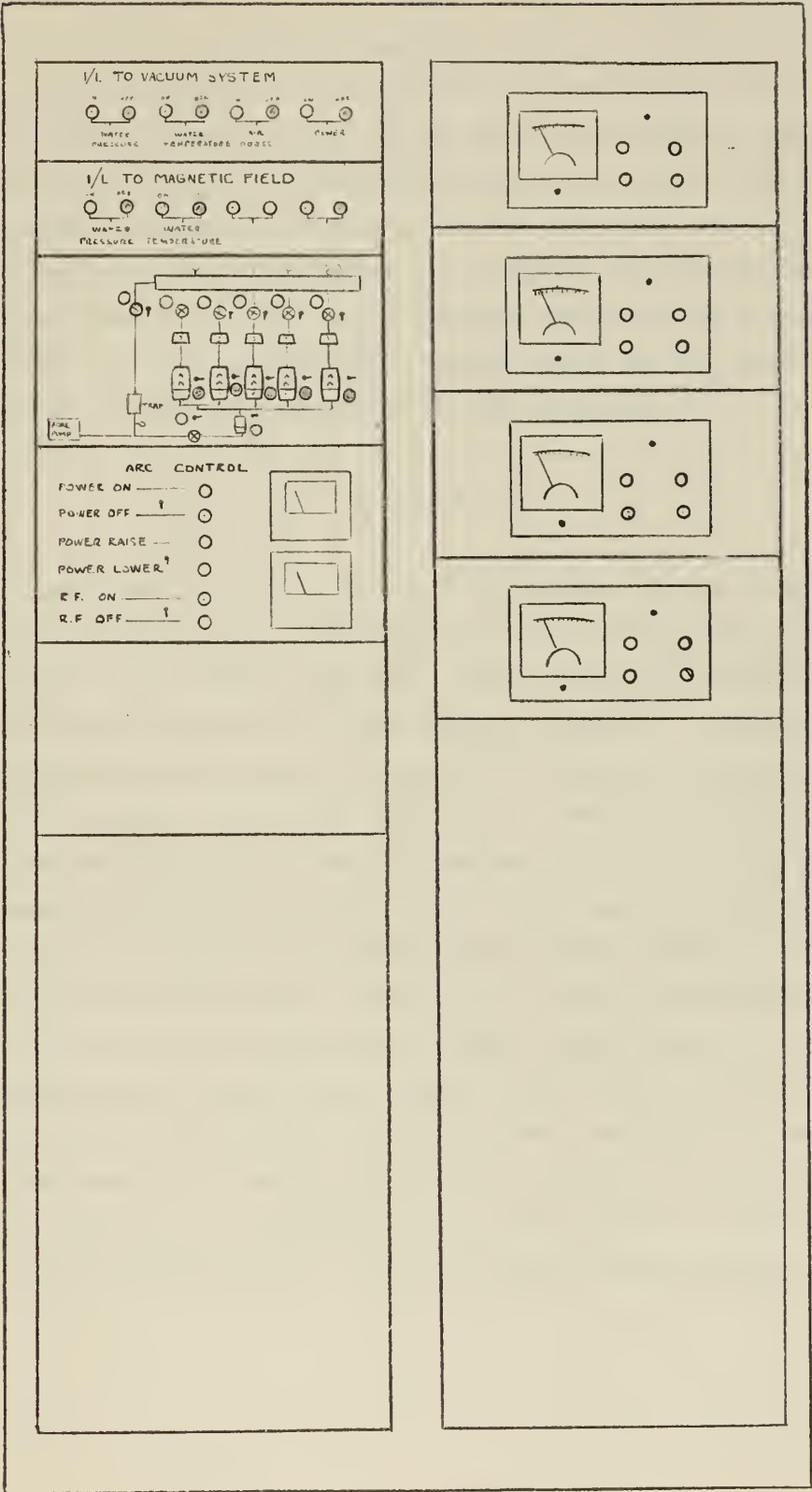

Fig. 7. Control Panel

The Magnetic Field

The primary objective of the plasma study facility is to provide a steady-state machine employing a variable magnetic field operating at any field up to a maximum of 10,000 gauss for continuous periods. This strong field with a steady-state plasma employing differential pumping and frequent access ports for diagnostic devices, purportedly makes this machine unique. Although an axial variation less than one percent was originally desired, the 2.5% figure was accepted for economy reasons.

The conditions for reflection of charged particles by a magnetic mirror is that the mirror ratio must exceed unity and $W_{\parallel 0}$ must be sufficiently small to make $W_{\parallel m}$ negative in the equation,⁵

$$W_{\parallel m} = W_{\parallel 0} - W_{\perp 0}(R-1).$$

Choosing a practical value for R, say 1.33, charged particle energies parallel to the field may be decreased by varying the anode-cathode potential until $W_{\parallel m}$ becomes negative. This condition should be manifested by a drop in pressure in the "burial chamber". A mirror ratio of 1.33 requires a peak mirror field of 13.3 kgauss to conform with the 10 kgauss in the main portion of the column. The mirror ratio can be increased by operating with a smaller magnetic field in the column.

The design of the coils providing a field distribution to satisfy the above specifications was not undertaken by the authors except for submission of the maximum axial length, 8.5 inches, and minimum inside diameter, 87 inches, for each magnet. These limitations were imposed by the pump-down and access ports spaced at 14 inch intervals. An extensive study of the field coil design, power supplies and water cooling requirements was made by Prof. A.W. Cooper of the US Naval Postgraduate School and is available.¹ At the time of writing, the contract for the manufacture of the coils had not been awarded.

Vacuum System

In order to maintain a steady-state plasma operating with a pressure of one to ten microns of Hg in the plasma source, a discharge current up to 150 amps, and a cathode-anode potential of 20-120 volts, the following requirements were established:

- (1). A vacuum system capable of maintaining a blank-off pressure of at least 1×10^{-6} mm Hg.
- (2). A configuration that will result in differential pumping over the length of the plasma column wherein the externally applied magnetic field is essentially constant.
- (3). An effective throughput of approximately $1500 \mu\text{Liter}/\text{sec}$ of He to provide the current anticipated.³
- (4). A pump-down time from atmospheric pressure on the order of one hour.
- (5). Ease of dis-assembly, relocation, and re-assembly of system components.
- (6). A system of interlocks to protect the system against accidental increase in pressure, loss of air pressure to the pneumatic gate valves, loss of cooling water, and loss of power.

In order to accomplish the above, the equipment shown schematically in Fig. 8 was purchased and installed as indicated. A list of vacuum components and their specifications is included in Appendix B. The maximum throughput of the booster pump is about $5000 \mu\text{lit}/\text{sec}$, which is less than the combined maximum throughput of the CVC and Veeco diffusion pumps by about 58%. Hence the booster pump is the limiting element in the system, but is of sufficient capacity to obtain the specified requirements.

The placement of the pumps was determined by the desirability of maintaining a pressure gradient along the length of the plasma column. A small amount of pumping speed control may be obtained by installation of a rheostat in the heater supply and to a lesser degree by throttle valves installed in the cooling water lines of each of the diffusion pumps.⁶ A disadvantage of the system is that oil may be sucked out of

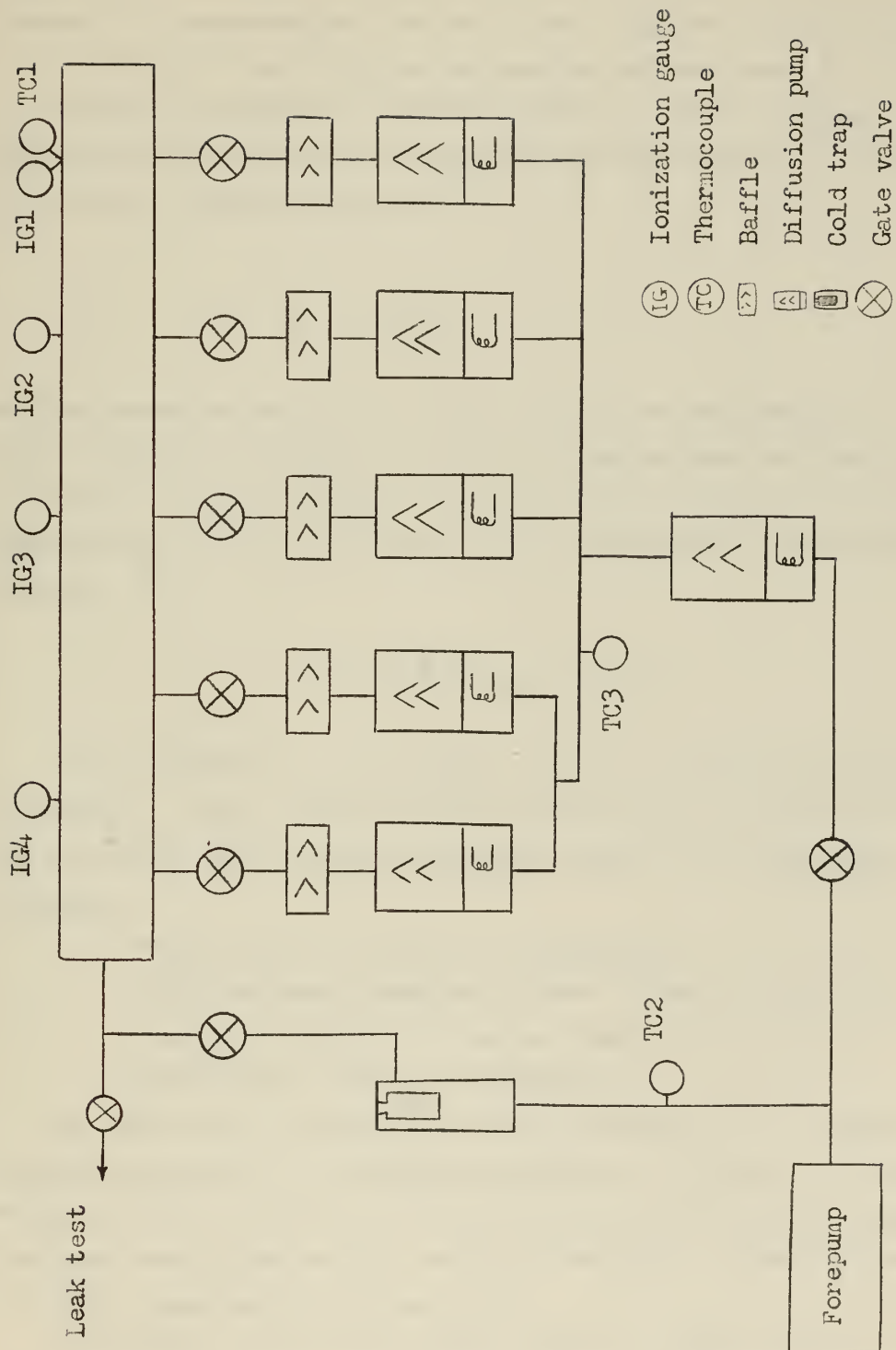

Fig. 8. Schematic of Vacuum System

one pump into another through the glass vacuum chamber. A solution would be to provide a manifold connecting the input sides of the diffusion pumps.⁶ Boron nitride baffles are inserted in the vacuum chamber to compartmentize the system and to promote differential pumping.

In order to make high-vacuum pumping calculations, it is necessary to ascertain the speed of the CVC baffle-Veeco diffusion pump combination. (CVC baffle-CVC diffusion pump speeds are made available by the manufacturer.) Using the formula,⁷

$$\frac{1}{C} = \frac{1}{S} + \frac{1}{S_p}$$

and the speed characteristic curves of the two manufactures,^{8,9} it is found that the throughput of the CVC diffusion pump and baffle combination is about 1.45 times as great as for the Veeco diffusion pump and baffle combination. In order to obtain the conductances of the plumbing, the formula,¹⁰

$$C = 0.25 \frac{D^3}{l} \bar{p} \quad (\mu \text{ lit/sec})$$

was used where D is in inches, l in feet, and \bar{p} , the mean pressure, in microns. After inserting correction factors to allow for elbow bends, the following operating pressures were found to be compatible with the equipment:

Forepressure to booster: 164 microns.

Inlet pressure immediately above booster: 98 microns.

Operating pressure in vacuum chamber: 5 microns.

For further details see Appendix B.

By bleeding He through the hollow cathode at 219 cc/min at 30 psia, the above pressure and throughput conditons can be met. A Fischer and Porter tri-flat variable area flow meter is to be used for measuring He flow-rate and a Hoke vernier valve for metering. Blank-off is maintained by a Veeco high-vacuum bellows valve.

The inside area of the vacuum chamber is about 25 ft.² Using the CVC high-vacuum calculator, it can be shown that the system could easily

pump down to 10^{-6} mm Hg under ideal conditions in a one hour period. Approximately three hours will be required to reach a vacuum in the order of 10^{-7} mm Hg.

The following interlocks are integrated into the vacuum system. A water-pressure actuated switch located in the cooling water line is provided to close the gate valves and disconnect the heater power supplies to the diffusion and booster pumps. This will prevent the oil from backstreaming into the vacuum chamber and cracking because of excessive heat. The gate valve solenoids are constructed to close when power is lost. However, it is noted that a 15 psi air pressure differential is required to close the valve. Hence an air pressure actuated switch is provided to cut off the heater power to the booster and diffusion pumps when the pressure to the pneumatic gate valves drops below 60 psig. As a result, backstreaming due to a malfunction concurrent with air-pressure loss will be minimized. In addition, the thermo-couple #1 circuit is modified so that when the system pressure accidentally exceeds 100 microns, the gate valves will close.

Flat rubber gaskets are used throughout the system except where O-rings and O-ring grooves were provided by manufacturers for seals in their equipment. Viton gaskets are used in the vacuum chamber and neoprene elsewhere. All gaskets were massaged with Apiezon vacuum grease, type T, and the excess wiped off. To insure solid flange contact with the gasket, a sealing surface was raised .03 inches on one flange face and ground to a #2 finish.

Figs. 4,5, and 6 present the block diagram and wiring details of the control and interlock circuits.

Mechanical Structure

The supporting structure for the vacuum chamber, vacuum system, and magnetic field coils, is made from Acme aluminum slotted angle and is sketched in Fig. 9. The original design assumed point loads of 1600 lbs. for each of six main field coils, 1200 lbs. for the mirror coil, 500 lbs. for the source coil, 100 lbs. for each diffusion pump, baffle, and gate valve assembly, and a miscellaneous 2,400 lb. distributed load. All point loads were multiplied by two in order to obtain effective distributed loads. A configuration of the structure was assumed and then computations were made to ascertain that the individual members could sustain the stresses involved. The computed load in each member was then compared with the manufacturer's crippling load data ¹¹ which involves a safety factor of 2.3. As a result, it was concluded that the assumed configuration would safely support the expected load. To increase rigidity and minimize deflection, additional members were added as can be seen in the photograph in Fig. 10.

All materials within four feet of the column axis are nonferrous in order that the magnetic field along the axis will not be distorted.

The vacuum chamber consists of four inch diameter pyrex glass crosses connected end to end as shown in Figs. 1 and 6. They are lapped with fiber-glass cloth tape and painted with epoxy resin as a safety precaution against implosion.

Weights are in pounds/section
Scale: 1 mm = 1 inch

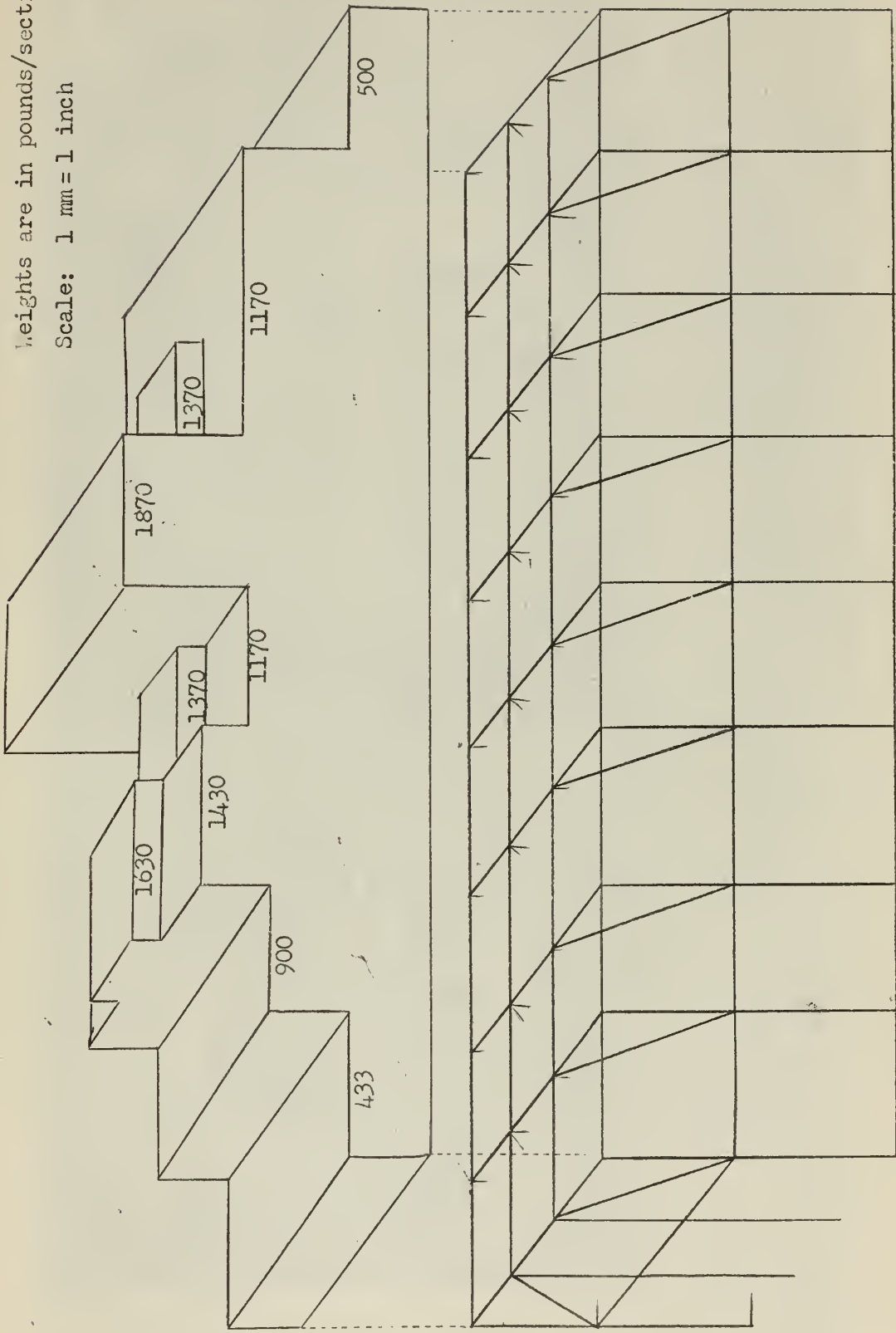

Fig. 9. Loading Diagram for Mechanical Structure

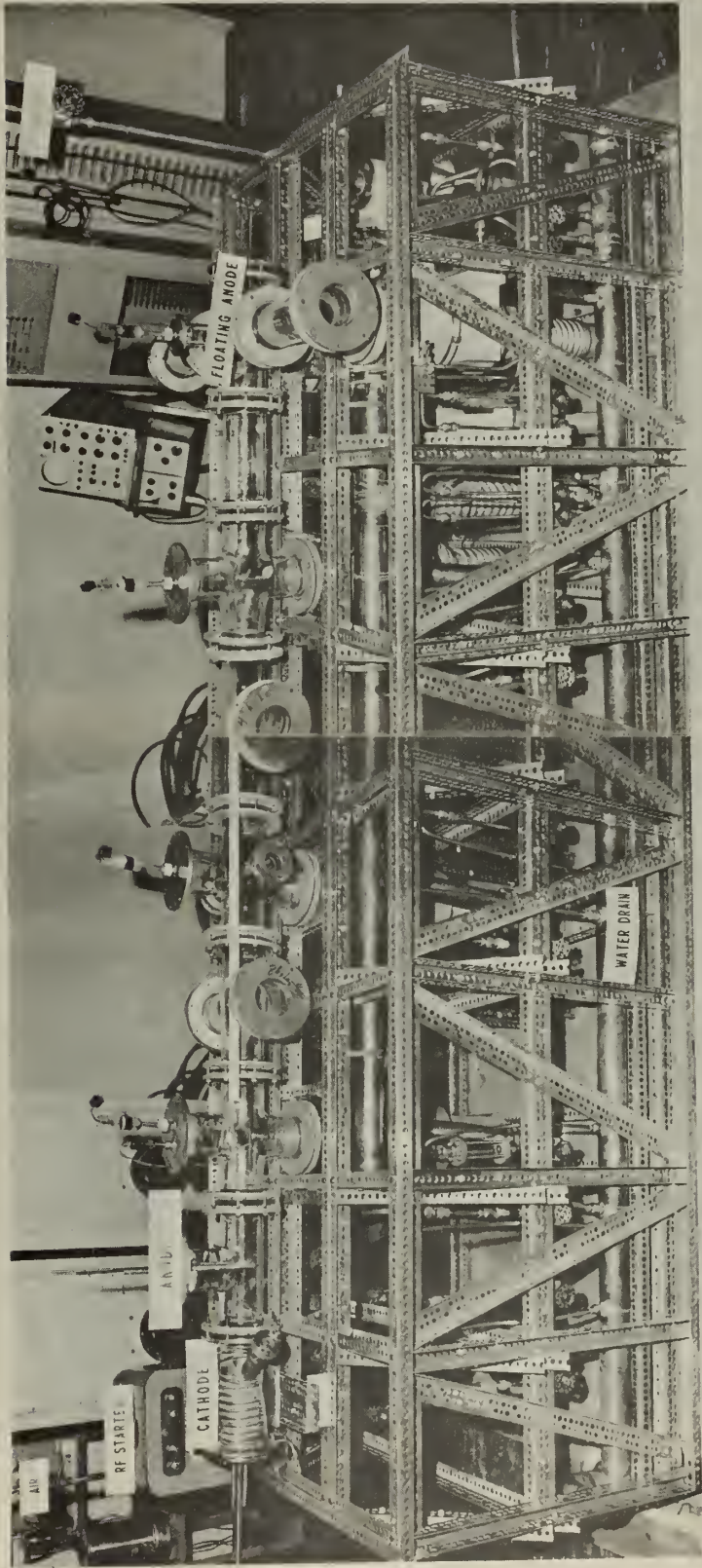

Fig. 10a. Composite photograph of machine and associated equipment.

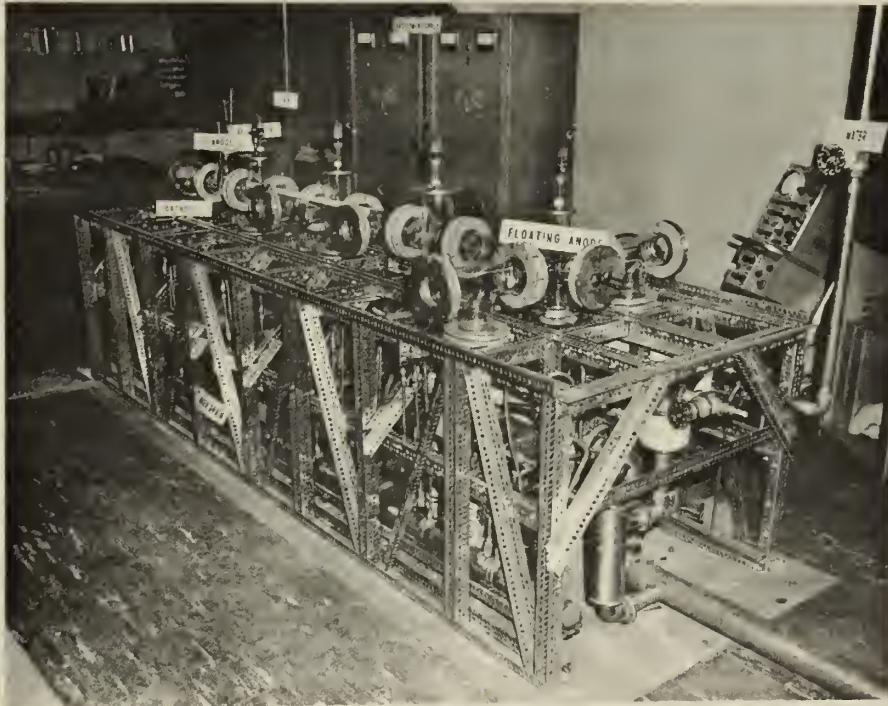
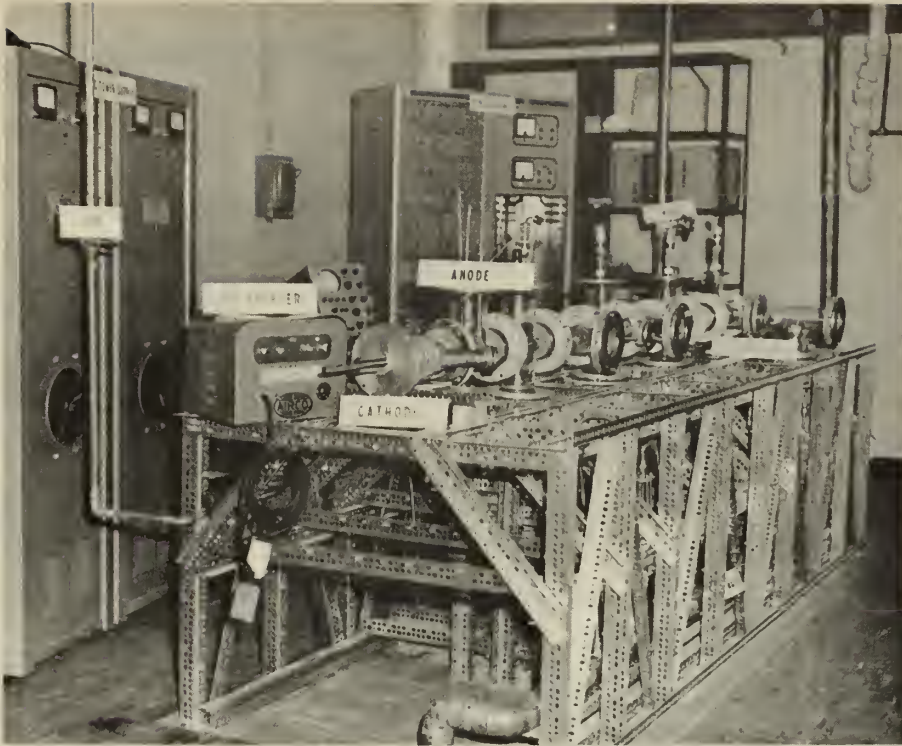

Fig. 10b. Photograph of machine and associated equipment

Appendix A

Operating Instructions and Recommendations for Future Modifications

The operating instructions included in this appendix are presented to enable personnel unfamiliar with the system to obtain a vacuum and establish a plasma. Following the operating instructions is a list of recommendations to improve the efficiency of the vacuum system if desired.

Obtaining a Vacuum:

1. Blow down high pressure air line to remove moisture.
2. Ensure presence of water-cooling flow to the fore pump.
3. Open the air pressure valve charging the pneumatic gate valve lines. (The air pressure line is interlocked such that pressures below 60 psi will cut out heater power to the booster and diffusion pumps.)
4. Fill the liquid nitrogen trap.
5. Start the fore pump with gate valve V6 open and all others closed. This will "rough-down" the vacuum chamber. Note that the open position on all valves is indicated by a light on the control panel.
6. When thermocouple TC1 reaches 100μ , close V6 and open V7. This pumps out the booster and diffusion pump fore-lines.
7. When TC3 reaches 100μ , open valves V1 through V5. This enables fore-pump "rough-down" of the entire system. Interlocks will prevent these gate valves from opening (except V5 which is manually operated) unless TC1 reads less than 100μ . In this event, further "rough-down" through V6 would be necessary.
8. Ensure that water cooling to the booster pump boiler is off by positioning the cooling valve handle in the horizontal position. Blow out the remaining water in the boiler cooling line with compressed air.
9. Turn on cooling water to all vacuum equipment. A water pressure tap located in the output side of baffle, B1, actuates a switch which will close all the pneumatic gate valves and disconnect the

heater power supplies to the booster and diffusion pumps in the event of low water pressure.

10. When TC1 and TC3 again reach 100μ , energize the booster heater. Steps three through seven and nine are pre-requisite to this step because of interlock switching in the heater circuits.
11. Allow eight minutes for the booster to reach steady-state conditions and then energize the heaters on the diffusion pumps. The "on" condition for all heaters is indicated by lights on the control panel. The above remark concerning interlocks in step 10 applies. It should take less than one hour to pump down to 10^{-6} mm Hg and about three hours to 10^{-7} mm Hg in the chamber.
12. Energize the ion gauges when the system pressure is less than one micron.
13. As the manual gate valve, V5, could not be integrated into the interlock system, it should be closed and the ion gauges de-energized whenever the system is left unattended. With these exceptions, the system may operate continuously. It is not necessary to maintain the liquid nitrogen supply in the coldtrap except when roughing-down through valve, V6.

Obtaining a Plasma:

1. Obtain a magnetic field of 200 gauss in the cathode region using the cathode source coil.
2. Apply 100 volts cathode-anode potential by use of the off-on switch and momentary raise-lower switch on the arc control panel. The raise-lower switch controls a motor which mechanically drives the rheostat in one of the two Sel-Rex rectifiers connected in series. As the maximum voltage output in either one of these is 60 volts, the other rectifier must be controlled manually to achieve changes in potential greater than 60 volts.
3. Establish a radio-frequency field in the cathode region. The intensity of the rf is pre-selected on the Airco rf starter unit. The frequencies generated by the spark-gap generator within the unit cover a wide-band and are inherent in the unit. The on-off switch is brought

to the control console for remote operation. As the cables carrying the rf make an effective transmitter, the rf should be applied for as short a time as possible. The operator should be aware of the Federal Communication Commission's regulations concerning this type of equipment. ¹²

4. The installation of the cooling water system to the electrodes is such that water will flow through the electrodes whenever water is flowing through the vacuum system components. The temperature of water leaving the cathode is monitored and actuates a switch cutting out the arc supply under excessive heating conditions.

Recommendations for Future Modifications:

1. Speed control of each individual diffusion pump is desirable to optimize the differential pumping scheme. A certain amount of control can be obtained by throttling the cooling water around the diffusion pump heaters and by inserting rheostats in the heater supplies. Valves are installed for this purpose. Addition of the rheostats would enable further control.
2. The pressure tap for the cooling water pressure interlock is located in the component furthest away from the water main input. Hence a drop in the building water main pressure would cause the interlock to function. A clogged up cooling line in any system component would, if anything, cause an increase in pressure at the pressure tap and the interlock would not function. Loss of water to a diffusion pump without interlock action would assuredly contaminate the system. Therefore, it is highly recommended that flow meters of the turbine type with electrical outputs should be installed in each diffusion pump cooling line causing the associated gate valve to close for loss of water pressure. Time involved in cleaning a dirty system should compensate for the extra cost. This would also provide a continuous and accurate determination of flow in these lines.
3. To obtain a better blank-off pressure (10^{-7} mm Hg) in the vacuum chamber, liquid nitrogen in place of water should be used to cool the baffles. This would involve a liquid nitrogen consumption of two lit/hr for the five baffles during equilibrium conditions.

4. Faster speeds can be obtained by replacing the present booster with an NRC Booster Diffusion pump type B-6 or its equivalent. Throughputs of approximately 40,000 μ lit/sec are possible with this type pump. ¹⁴

Appendix B-

Vacuum Systems, Component Specifications and Calculations

Component Specifications. (All components are for 4" plumbing unless otherwise specified.)

Diffusion pumps:

Three Veeco, oil fractionating, charged with 200 cc Octoil, rated at 400 lit/sec at .05 microns Hg. ^{9,13}

Two CVC, PMC-720, oil fractionating, charged with 400 cc Octoil, rated at 720 lit/sec at 0.1 microns.

Booster pump: Literature has been requested from the manufacturers on the characteristics of these pumps when charged with silicone based oils.

One NRC, B-4, type 126 B, oil fractionating, charged with 375 cc of Narcoil-10, rated at 240 lit/sec at 10 microns and throughput of 5000 μ lit/sec. ¹⁴

Mechanical fore-pump:

One Kinney, KDH 130, single stage, rated at 130 CFM. ¹⁵

Gate valves:

All are Kinney, series G.

Four 4", one 6", one 2", solenoid controlled, pneumatically operated. One 4" manually controlled. All valves are set to close for loss of power to the solenoid. ¹⁶ They were timed to close completely in two seconds after loss of power.

Baffles:

Five CVC, type BC, multi-coolant (liquid nitrogen, freon, of water). ¹⁷ Water is to be used as the coolant for which backstreaming may be reduced to 0.1%.

Cold trap:

One Veeco, type CT, 2", stainless steel bucket.

Pressure sensors:

Four ionization gauges, CVC type GIC-110, using VG-1A sensing tubes, modified with alarm circuits and two station thermocouple units. Operate over a pressure range of one micron to 2×10^{-9} mm Hg.

Three thermocouples, CVC Type GTC-004.

Calculations.

Throughput:

$$Q_{\text{system}} = Q_{\text{booster}} = Q_{\text{forepump}} = Q_{\text{diffusion pumps}} \quad (1)$$

From manufacturers' data,^{8,9,14,15} the maximum throughputs under optimum conditions for specified components are as follows:

| | |
|----------------------|----------------------|
| Booster | 5000 micron-lit/sec |
| Forepump | 42000 micron-lit/sec |
| CVC diffusion pump | 3000 micron-lit/sec |
| Veeco diffusion pump | 2250 micron-lit/sec |

Hence the maximum system throughput that may be obtained is about 5,000 μ lit/sec. For this throughput, the forepump must operate at 103 CFM and at 120 microns.

Operating pressures:

Assuming vacuum chamber pressure equal 1.7 microns, and using the formula⁷

$$\frac{1}{C} = \frac{1}{S} + \frac{1}{S_p}, \quad (2)$$

C_b may be obtained for the baffle-Cvc diffusion pump combination using the manufacturer's speed curves,²⁰ and is found to be 1150 lit/sec. Using formula (2) and manufacturer's speed curves,⁹ the speed of the Baffle-Veeco diffusion pump may be found to be 291 lit/sec.

$$Q = S P, \quad (3)$$

$$\frac{Q_{b-cvc dp}}{Q_{b-veeco dp}} = \frac{1.7 \mu 750 \text{ lit/sec}}{1.7 \mu 495 \text{ lit/sec}} = 1.5$$

Repeating the above, and assuming vacuum chamber pressure = 0.1 microns, obtain:

$$\frac{Q_{b-cvcdp}}{Q_{b-veecdp}} = 1.3$$

and for chamber pressure = 10 microns

$$\frac{Q_{b-cvcdp}}{Q_{b-veecdp}} = 1.52$$

Therefore,

$$\frac{Q_{b-cvcdp}}{Q_{b-veecdp \text{ avg}}} = 1.45 \quad (4)$$

From formula (1),

$$Q_{\text{total}} = 3Q_{b-veecdp} + 2Q_{b-cvcdp} = 5,000 \mu\text{lit/sec}$$

for optimum conditons. Using (4),

$$Q_{b-veeco dp} = 850 \mu\text{lit/sec}$$

$$Q_{b-cvc dp} = 1230 \mu\text{lit/sec}$$

From (3) and manufacturer's data, ²⁰ the vacuum operating pressure is found to be 3 microns.

Pressures in other parts of the system compatible with the above may be found as follows:

The formula for the conductance of a round long pipe is, ¹⁰

$$C = .25 \frac{D^4}{l} \bar{p}$$

where D is in inches, l in feet, and \bar{p} in microns. Using ¹⁰

$$L_{\text{eff}} < L_{\text{act}} + 1.33D,$$

(where D and L are in the same units) to correct the actual length of pipe for the effect of elbows, the following is found:

Effective length of 4" pipe, forepump to booster: 24'. $\bar{p} = 120$ microns, having used (3).

Therefore, $C = 324 \text{ lit/sec.}$

From (2),

$$\frac{1}{S} = \frac{1}{C} + \frac{1}{S_p} = \frac{1}{294} + \frac{1}{48.6}$$

Hence the forepump and its associated plumbing may be replaced by an "ideal" pump with $S = 42.2 \text{ lit/sec.}$ For $Q = 5,000 \mu\text{lit/sec,}$ the pressure at the output of the booster would then be 118 microns.

From the booster speed curves, ¹⁴ input pressure is 60 microns.

Appendix C

Tabulation of Cost Data

Expenditures

| | |
|---------------------------------|----------------|
| a. Plasma Source | \$ 466.77 |
| b. Vacuum System | 13008.84 |
| c. Support Structure | 899.41 |
| d. Labor | 2640.00 |
| e. Miscellaneous | 4052.48 |
| f. Public Works (M and O funds) | <u>3366.00</u> |
| Total | \$24,433.50 |

Estimated Future Expenditures

| | |
|-------------------------|----------------|
| a. Magnetic field coils | \$19290.00 |
| b. Power rectifiers | 37600.00 |
| c. Mirror coil | 2285.00 |
| d. Cooling system | <u>5506.00</u> |
| Total | \$64,681.00 |

Total Estimated Cost of System \$89,114.50

General Bibliography

1. Glasstone, Samuel, and Lovberg, R.H., Controlled Thermonuclear Reactions, prepared under auspices of the Office of Technical Information, United States Atomic Energy Commission.
2. Dushman, Saul, Scientific Foundations of Vacuum Technique, J. Wiley, New York, 1949.
3. Guthrie, A. and Wakerling, R.K., Vacuum Equipment and Techniques, McGraw Hill Book Co., New York, 1949.

References

1. Cooper, A.W., Proposal for Air-Core Magnet System for Steady-State Plasma Study Facility, memorandum to Research Council, Apr 9, 1962.
2. Rose, D.J., et al, Highly Ionized Cathode Discharge, preprint for Journal of Applied Physics.
3. Gardner, A.L., et al, P-4, A Steady-State Plasma System, UCRL 5904, May 1960.
4. Neigdigh, R.V., and Weaver, C.H., Proceedings, Second Conference on Peaceful Uses of Atomic Energy, Vol 31, pg 315, (1958).
5. Glasstone and Lovberg, Controlled Thermonuclear Reactions, see bibliography.
6. J.D. Burden, CVC representative, interview, Mar 1962.
7. Hall, Lewis D., A Little Bit About Almost Nothing, distributed by ULTEK Corp.
8. CVC Instruction Bulletin, #6-92-A.
9. Veeco, "400" series Catalogue.
10. Guthrie, Vacuum Equipment and Techniques, see bibliography.
11. Acme Steel, AIM brand, Slotted Angle Construction Handbook.
12. Airco 500/1000 High Frequency Oscillator Instructions and Parts Manual 2304, Feb 1961.
13. Veeco, "400" Series Catalogue.
14. NRC Equipment Corporation, Installation and Operating Instructions for B-4 Booster Pump, Type 126B, May 1957.

15. Kinney Manufacturing Div., Instructions 3120.8J, July 1959.
16. Kinney Manufacturing Div., Instruction Bulletin #3420.8, Nov 1958.
17. Consolidated Vacuum Corporation, Instruction Bulletin #10-18-B.
18. NRC Equipment Corp., Bulletin DP 5.
19. Consolidated Vacuum Corporation, Instruction Bulletin #9-82-A.
20. Consolidated Vacuum Corp., Bulletin 6-1.

thes825

Design and construction of a steady stat



3 2768 002 02077 8

DUDLEY KNOX LIBRARY